

## **RANGER** IW-140; IW-160; IW-205; IW-220 INSULATOR WASHER BOOM TRUCK



THE RANGER INSULATOR WASHER BOOM TRUCK mounts onto a wide range of chassis types to suit all applications. It is available with a skid mounted insulator washer pump and engine module and removable water storage tank up to 10,000 litre capacity with 4 main boom options at 14; 16; 20.5 and 22m working heights.



### RANGER IW SERIES

This 2 boom articulating aerial device is used in combination with the TRANSLINK Insulator Washer Skid unit and water tank to give a fully integrated Insulator Washer Boom Truck capable of washing insulators up to 500kV. The boom complies with ANSI A92.2 standards Category "C" (46kV) and the Insulator Washer to IEEE-957 International Standards - optional Category B (69kV).

### Standard Features – Boom

- ◆ Two person end-mount platform
- ◆ Power assist control system with demand throttle
- ◆ One hand operation at platform
- ◆ Individual lever controls at base
- ◆ Hydraulic platform tilt at base and platform controls
- ◆ Hydraulic master / slave platform levelling
- ◆ Insulated booms
- ◆ Pilot operated closed centre hydraulic system
- ◆ 135 litre hydraulic tank capacity
- ◆ Lock valves on all hydraulic cylinders
- ◆ 360° continuous rotation
- ◆ Four hydraulic stabilisers with stabiliser /boom interlocks
- ◆ Power by PTO unit fitted to vehicle with interlock indicator
- ◆ Safety harness points (2) in cage
- ◆ 12 volt auxiliary let down system at base
- ◆ Translink "plug and go" insulator washer control panel.

**SIMPLY RELIABLE**

# RANGER IW-140; IW-160; IW-205; IW-220

## INSULATOR WASHER BOOM TRUCK

### Features and Options



Single handed control in basket for total command of all boom operations



Optional connector for cage mounted wash gun with quick release coupling and hose along booms.



Electric rewind hose-reel (50m) with quick release connectors and hose guide



Optional Semi-elliptical storage tanks with capacities up to 8,500 litres



Skid mounted engine and pump module with control panel and 2 electric rewind hose-reels



Standard rectangular storage tanks with capacities up to 10,000 litres



High-pressure stainless steel wash guns with 1 / 4; 5/16 and 7/32 inch nozzle options. All parts interchangeable.



Two-man fully insulated basket and boom for washing safely at heights up to 22m and on live lines up to 500kV with the Translink proven insulator washer system.

### Range Of Movement

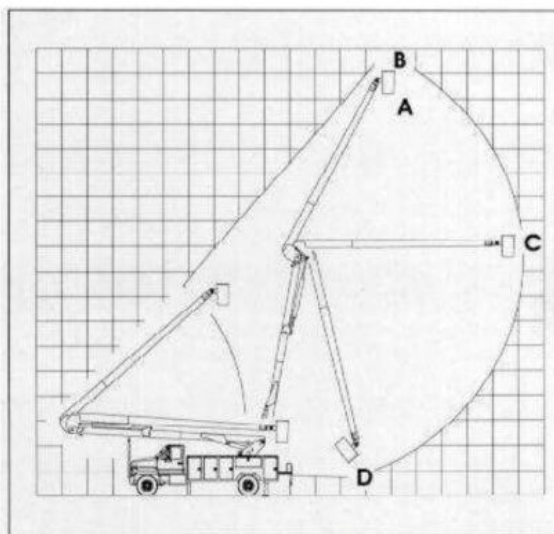

### SPECIFICATIONS

RANGER Model Code		IW-140	IW-160	IW-205	IW-220
Platform Height	A	12.4m	14.0m	18.5m	20.0m
Working Height	B	14.4m	16.0m	20.5m	22.0m
Maximum Outreach	C	8.0m	9.0m	11.9m	12.7m
Max. SWL		318kg	272kg	318kg	318kg
Lower Boom Articulation		102°	102°	102°	102°
Upper Boom Articulation		163°	163°	163°	163°
GVW Minimum		10.0t	12.0t	15.0t	15.0t
Wheelbase Minimum		3.95m	4.50m	4.88m	4.88m

**TRANS LINK International Sales Ltd.,**  
 The Pigpen, Mill Farm, Farlow, Kidderminster, Worcestershire, DY14 0LP. UK  
 Tel : +44 (0)1746 718 740 Fax : +44 (0) 1746 718 540  
 E-mail: [translink-international@dial.pipex.com](mailto:translink-international@dial.pipex.com)  
[www.translink-international.com](http://www.translink-international.com)